

ANILLOS DE APOYO PB

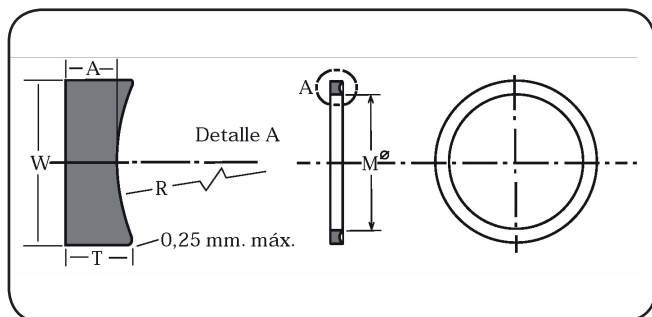

CARACTERÍSTICAS PRINCIPALES

Los ARO-DUROS PB de contra presión, se montan conjuntamente con las juntas tóricas. Sin embargo, no son juntas. Las juntas tóricas se montan deformadas diametralmente en su sección, por la fuerza ejercida por las superficies de contacto. Debido a la reacción elástica de la junta deformada, está llena elásticamente el espacio y la rugosidad de las superficies de contacto, consiguiendo un cierre perfecto (Fig 1). Al entrar en funcionamiento el sistema y aparecer la presión, la junta tórica es desplazada dentro de la ranura y deformada (Fig 2) consiguiéndose así una mayor efectividad elástica del cierre. Sin embargo, al alcanzarse determinados valores de presión, se produce una situación límite para la junta que comienza a extrusionarse (Fig 3). Para valores de presión superiores, la junta es introducida en el juego natural existente entre ambas superficies y al dejar de actuar la presión o cambiar de sentido y repetirse el ciclo de trabajo, la junta termina siendo pellizcada y dañada (Fig 4), perdiéndose la efectividad del cierre e incorporándose partículas de caucho al circuito hidráulico con la posibilidad de producir graves problemas en los elementos de control del mismo.

PB

DESCRIPCIÓN

Anillos de apoyo para O-Ring

MATERIAL DE SUPERFICIE DINÁMICA

NBR

CONDICIONES DE EJERCICIO

Dureza: 90 Sh. D

Temperatura: -30°C + 120°C..

CARACTERÍSTICAS PRINCIPALES

Este fenómeno de la extrusión de la junta, depende de los valores de presión, dureza de la junta y juego entre las superficies en contacto. El fenómeno de la extrusión, se evita mediante la utilización de ARO-DUROS PB de contrapresión. Al ser elementos elásticos de mayor dureza, el fenómeno desaparece para los mismos valores de presión y juego. Los ARO-DUROS PB, son perfiles continuos, sin empalmes ni rebabas, tienen estrechas tolerancias de acabado y pueden estirarse al montarlos.

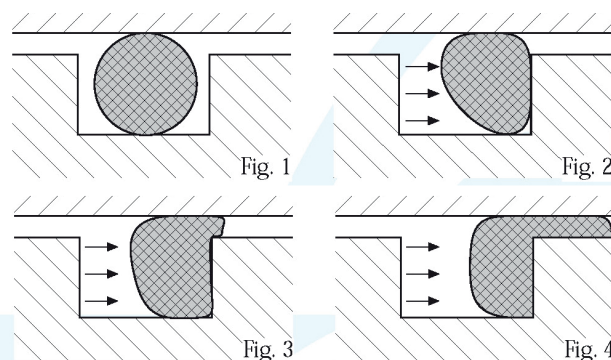

	ESPEJOR	W	T
O-Ring	1,78	1,35	1,40
O-Ring	2,62	2,18	1,40
O-Ring	3,53	3,00	1,40
O-Ring	5,33	4,65	1,90
O-Ring	6,99	5,99	2,80

PB

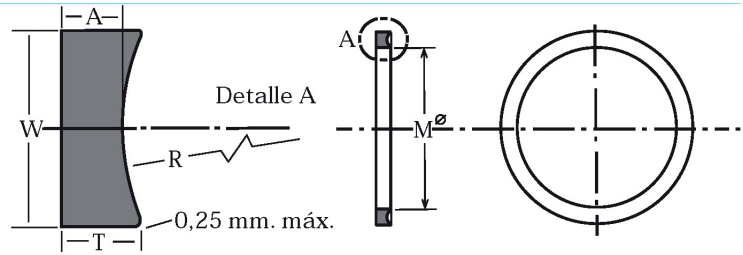

Referencia	Medida	O - Ring
PB 4	1,78	x 1,78
PB 5	2,57	x 1,78
PB 6	2,90	x 1,78
PB 7	3,68	x 1,78
PB 8	4,48	x 1,78
PB 9	5,28	x 1,78
PB 10	6,07	x 1,78
PB 11	7,66	x 1,78
PB 12	9,25	x 1,78
PB 13	10,82	x 1,78
PB 14	12,42	x 1,78
PB 15	14,00	x 1,78
PB 16	15,60	x 1,78
PB 17	17,17	x 1,78
PB 18	18,77	x 1,78
PB 19	20,35	x 1,78
PB 20	21,95	x 1,78
PB 21	23,52	x 1,78
PB 22	25,12	x 1,78
PB 23	26,70	x 1,78
PB 24	28,30	x 1,78
PB 25	29,87	x 1,78
PB 26	31,47	x 1,78
PB 27	33,05	x 1,78
PB 28	34,65	x 1,78
PB 29	37,82	x 1,78
PB 30	41,00	x 1,78
PB 31	44,17	x 1,78
PB 32	47,35	x 1,78
PB 33	50,52	x 1,78
PB 34	53,70	x 1,78
PB 35	56,87	x 1,78
PB 36	60,05	x 1,78
PB 37	63,22	x 1,78
PB 38	66,40	x 1,78
PB 39	69,57	x 1,78
PB 40	72,75	x 1,78
PB 41	75,92	x 1,78
PB 42	82,27	x 1,78
PB 43	88,62	x 1,78
PB 44	94,97	x 1,78

Referencia	Medida	O - Ring
PB 45	101,32	x 1,78
PB 46	107,67	x 1,78
PB 47	114,02	x 1,78
PB 48	120,37	x 1,78
PB 49	126,72	x 1,78
PB 50	133,07	x 1,78
PB 106	4,42	x 2,62
PB 107	5,23	x 2,62
PB 108	6,02	x 2,62
PB 109	7,60	x 2,62
PB 110	9,19	x 2,62
PB 156	10,62	x 2,62
PB 111	10,78	x 2,62
PB 112	12,37	x 2,62
PB 113	13,95	x 2,62
PB 114	15,54	x 2,62
PB 115	17,13	x 2,62
PB 116	18,72	x 2,62
PB 117	20,29	x 2,62
PB 118	21,89	x 2,62
PB 119	23,47	x 2,62
PB 120	25,07	x 2,62
PB 121	26,64	x 2,62
PB 122	28,25	x 2,62
PB 123	29,82	x 2,62
PB 124	31,42	x 2,62
PB 125	32,99	x 2,62
PB 126	34,59	x 2,62
PB 127	36,17	x 2,62
PB 128	37,77	x 2,62
PB 129	39,34	x 2,62
PB 130	40,94	x 2,62
PB 131	42,52	x 2,62
PB 132	44,12	x 2,62
PB 133	45,69	x 2,62
PB 134	47,29	x 2,62
PB 135	48,90	x 2,62
PB 136	50,47	x 2,62
PB 137	52,07	x 2,62
PB 138	53,65	x 2,62

Referencia	Medida	O - Ring
PB 139	55,25	x 2,62
PB 140	56,82	x 2,62
PB 141	58,42	x 2,62
PB 142	60,00	x 2,62
PB 143	61,60	x 2,62
PB 144	63,17	x 2,62
PB 145	64,77	x 2,62
PB 146	66,35	x 2,62
PB 147	67,95	x 2,62
PB 148	69,52	x 2,62
PB 149	71,12	x 2,62
PB 150	72,69	x 2,62
PB 151	75,87	x 2,62
PB 152	82,22	x 2,62
PB 153	88,57	x 2,62
PB 154	94,93	x 2,62
PB 155	101,27	x 2,62
PB 157	113,97	x 2,62
PB 158	120,32	x 2,62
PB 159	126,67	x 2,62
PB 160	133,02	x 2,62
PB 161	139,37	x 2,62
PB 162	145,72	x 2,62
PB 163	152,07	x 2,62
PB 164	158,42	x 2,62
PB 165	164,77	x 2,62
PB 166	171,13	x 2,62
PB 167	177,47	x 2,62
PB 168	183,82	x 2,62
PB 169	190,17	x 2,62
PB 170	196,52	x 2,62
PB 171	202,87	x 2,62
PB 172	209,22	x 2,62
PB 173	215,57	x 2,62
PB 174	221,93	x 2,62
PB 175	228,28	x 2,62
PB 176	234,63	x 2,62
PB 177	240,98	x 2,62
PB 178	247,33	x 2,62
PB 210	18,64	x 3,53

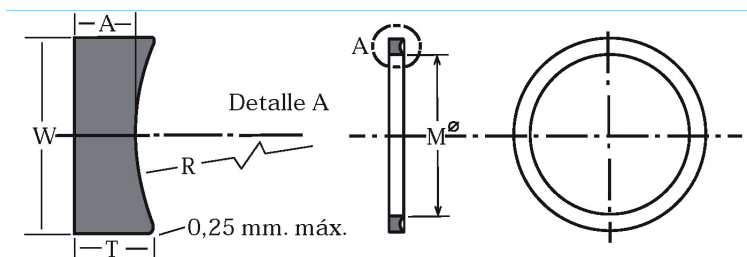
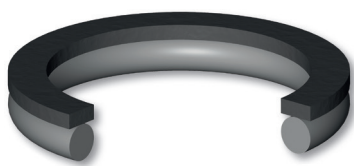
PB

Referencia	Medida	O - Ring
PB 211	20,22	x 3,53
PB 212	21,82	x 3,53
PB 213	23,40	x 3,53
PB 214	24,99	x 3,53
PB 215	26,58	x 3,53
PB 216	28,17	x 3,53
PB 217	29,75	x 3,53
PB 218	31,34	x 3,53
PB 219	32,92	x 3,53
PB 220	34,52	x 3,53
PB 221	36,10	x 3,53
PB 222	37,69	x 3,53
PB 223	40,87	x 3,53
PB 224	44,04	x 3,53
PB 225	47,22	x 3,53
PB 226	50,40	x 3,53
PB 227	53,57	x 3,53
PB 228	56,74	x 3,53
PB 229	59,92	x 3,53
PB 230	63,09	x 3,53
PB 231	66,27	x 3,53
PB 232	69,44	x 3,53
PB 233	72,62	x 3,53
PB 234	75,80	x 3,53
PB 235	78,97	x 3,53
PB 236	82,14	x 3,53
PB 237	85,32	x 3,53
PB 238	88,50	x 3,53
PB 239	91,67	x 3,53
PB 240	94,84	x 3,53
PB 241	98,02	x 3,53
PB 242	101,20	x 3,53
PB 243	104,37	x 3,53
PB 244	107,54	x 3,53
PB 245	110,72	x 3,53
PB 246	113,90	x 3,53
PB 247	117,07	x 3,53
PB 248	120,25	x 3,53
PB 249	123,42	x 3,53
PB 250	126,60	x 3,53
PB 251	129,77	x 3,53

Referencia	Medida	O - Ring
PB 252	132,94	x 3,53
PB 253	136,12	x 3,53
PB 254	139,29	x 3,53
PB 255	142,47	x 3,53
PB 256	145,65	x 3,53
PB 257	148,82	x 3,53
PB 258	151,99	x 3,53
PB 259	158,34	x 3,53
PB 260	164,69	x 3,53
PB 261	171,04	x 3,53
PB 262	177,39	x 3,53
PB 263	183,74	x 3,53
PB 264	190,10	x 3,53
PB 265	196,44	x 3,53
PB 266	202,79	x 3,53
PB 267	209,14	x 3,53
PB 268	215,49	x 3,53
PB 269	221,84	x 3,53
PB 270	228,19	x 3,53
PB 271	234,54	x 3,53
PB 272	240,89	x 3,53
PB 273	247,24	x 3,53
PB 274	253,59	x 3,53
PB 275	266,29	3,53
PB 276	279,00	x 3,53
PB 277	291,69	x 3,53
PB 278	304,39	x 3,53
PB 279	329,79	x 3,53
PB 280	355,19	x 3,53
PB 281	380,60	x 3,53
PB 325	37,47	x 5,33
PB 326	40,65	x 5,33
PB 327	43,82	x 5,33
PB 328	47,00	x 5,33
PB 329	50,16	x 5,33
PB 330	53,34	x 5,33
PB 331	56,52	x 5,33
PB 332	59,69	x 5,33
PB 333	62,87	x 5,33
PB 334	66,04	x 5,33

Referencia	Medida	O - Ring
PB 335	69,22	x 5,33
PB 336	72,40	x 5,33
PB 337	75,57	x 5,33
PB 338	78,74	x 5,33
PB 339	81,92	x 5,33
PB 340	85,09	x 5,33
PB 341	88,27	x 5,33
PB 342	91,44	x 5,33
PB 343	94,62	x 5,33
PB 344	97,80	x 5,33
PB 345	100,97	x 5,33
PB 346	104,14	x 5,33
PB 347	107,32	x 5,33
PB 348	110,49	x 5,33
PB 349	113,67	x 5,33
PB 350	116,84	x 5,33
PB 351	120,02	x 5,33
PB 352	123,19	x 5,33
PB 353	126,37	x 5,33
PB 354	129,54	x 5,33
PB 355	132,72	x 5,33
PB 356	135,89	x 5,33
PB 357	139,07	x 5,33
PB 358	142,24	x 5,33
PB 359	145,42	x 5,33
PB 360	148,60	x 5,33
PB 361	151,77	x 5,33
PB 362	158,12	x 5,33
PB 363	164,47	x 5,33
PB 364	170,82	x 5,33
PB 365	177,17	x 5,33
PB 366	183,52	x 5,33
PB 367	189,87	x 5,33
PB 368	196,22	x 5,33
PB 369	202,57	x 5,33
PB 370	208,92	x 5,33
PB 371	215,27	x 5,33
PB 372	221,62	x 5,33
PB 373	227,97	x 5,33
PB 374	234,32	x 5,33
PB 375	240,67	x 5,33